

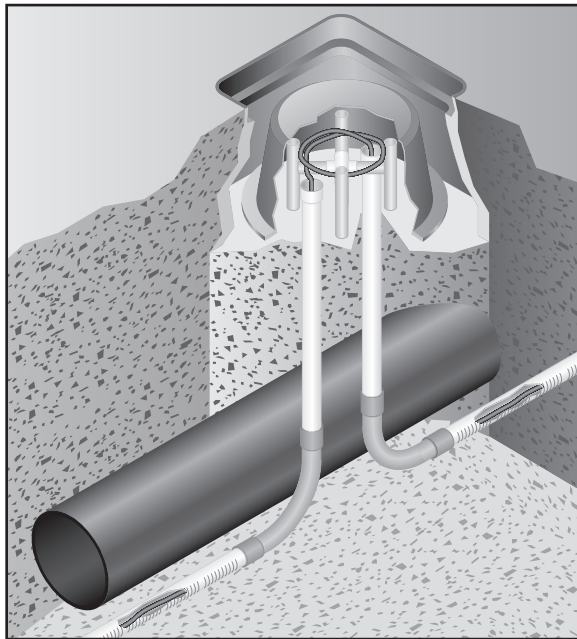

TT5000-HS (for fuel leaks)
TT5001-HS (for solvent leaks)
TraceTek Sensing Cable for Underground Leak Detection



Installation Instructions

General Instructions

These instructions explain the proper procedures for installing and testing TraceTek TT500X-HS sensing cables. (TT500X-HS refers to either TT5000-HS or TT5001-HS). TT500X-HS sensing cables are primarily intended for use in underground (fuel or solvent) pipeline applications. TT500X-HS sensing cables ignore water but will detect and locate (fuel or solvent) spills and leaks. (See the data sheet for specific performance characteristics.)

Important Notes

When used to monitor underground fuel pipelines, TT500X-HS sensing cables are typically installed within slotted conduit that is routed alongside the main pipeline. TT500X-HS sensing cable is designed for use within slotted PVC conduit and is constructed with an outer layer of polyethylene fibers to provide extra pulling strength and low friction during the installation process. The sensor cable core is standard TT5000 (for fuel) or TT5001 (for solvent) with well documented response times, numerous third party qualifications and years of successful applications.

- TT5000-HS sensing cable is identified by the all white color of the outer jacket.
- TT5001-HS sensing cable is identified by a purple tracer in the white outer jacket.

Tools Required

- TT-PTB-1000 (part # 486437-000) Portable Test Box, battery powered instrument specifically designed for testing and trouble shooting TraceTek systems
- Ohmmeter (>20 M ohm) Can be used as an alternative and supplement to the PTB 1000
- TT-MAPPING CAP-MC (part # P000000871) Used to simulate leaks at connector points during commissioning and mapping process
- Extra TT-MLC-MC-BLK (part # 133332-000) Leader cable. Used with the ohmmeter to make connections to the sensor cable for resistance measurements
- Extra TT-MET-MC (part # 571293-000) End termination. Used during installation or to temporarily isolate a sub-section of sensor cable for resistance measurements
- TT-Kellems-Grip-Large (part # P000001291) Large Kellems Grip used in cable pulling when rope overbraid loop not available.
- TT-ULTRA-TORCH (part # 390067-000) Flameless heating tool (Ultratorch 200) or suitable heat gun with concentrator tip.

Required Materials

- Conduit cleaning tool Used in proofing installed sections of conduit.
- Conduit end caps Used to cover exposed conduit end to maintain conduit cleanliness.
- Heat shrink tubing segments Used as environmental seal over all mated male/female (pin/socket) connections

Optional Materials

- TT-MBC-MC-TW (part # P000001206) Branch connector designed for rugged outdoor applications used to connect and branch "T" lines
- TT-MJC-XX-MC-BLK Jumper cable is available in various pre-cut and terminated lengths
- TT5000-HUV-CK-MC-M/F (part # P000001207) Connector kit used during field connection of TT500X-HS bulk cable

General Notes: Do's and Don'ts:

DO:

- Store the cable in its original container in a clean, dry area until ready to install.
- Schedule the sensor cable installation as late as possible in the construction schedule to avoid risk of damage or contamination by other contractors or construction tasks.
- Remove cable from the pipe if any thread cutting, welding, soldering or similar pipe fitting work will be performed.

DON'T:

- Drag the cable through water, paint, solvents, oil or other contaminants.
- Install damaged or contaminated sensing cable.
- Exceed the maximum pulling force of 100 kg (220 lb).
- Use the cable as a rope for lifting or securing any object.
- Allow tools or heavy objects to fall on cable.
- Exceed 3300 ft (1000 m) of individual sensor cable circuit length when using a SIM alarm module.
- Test the cable with fuel.
- Use tie wrap or wire to secure the cable.

TT5000-HS and TT5001-HS Sensing Cable Installation Instructions

Installation

1

Prepare the conduit and pull rope.

- Verify that major construction is complete.
- Verify conduit and pull rope has been installed properly. Reference TraceTek document H58175 for general information.

Note that conduit dimensions and related parts can vary between projects.

2a

Conduit Cleaning:

- Even if the conduit was proofed with a conduit cleaning tool during the conduit installation process, it is recommended to clean and check clearance of the conduit immediately before installing cable in order to avoid damaging the cable.
- Attach a rope section with a rag tied to the eye splice in advance of the sizing tool.



2b

- Verify that the pull rope is free of knots and splices and that there is 6 feet of extra rope at both ends of each section.
- Two people are needed to manage the pull rope. One person is on each end of the end pull rope, and each person must be able to communicate with the other in case of problems during the pull.
- The person feeding the pull rope into conduit needs to maintain slack at all times.
- Pull the sizing tool from one end of the conduit section to the other.



2b *cont'd*

- Verify that the sizing tool pulls freely through each section of conduit. Pull with a slow steady motion. Do not use excessive force on the pull rope, as this could damage the conduit.
- As you pull, coil the pull rope by hand and keep the pull rope out of the dirt by placing it on cardboard or plastic sheeting.
- If the pull rope becomes stuck, do not increase pull force—instead pull the rope in opposite direction for a short distance, then try repulling in original direction with normal force.
- Shake the rag attached to the sizing tool free of excess debris. Remove the rope section containing the rag from the sizing tool. Replace the rag with a clean rag if necessary, and then attach the rope section with the rag to the eye splice in advance of the sizing tool.
- Reverse the pulling direction to bring the sizing tool through the conduit in the opposite direction, and return the original pull rope back into the conduit. Remove the sizing tool and rope section with rag from the pull rope.
- Verify conduit ends are marked for example, with different color conduit endcaps or tape to indicate direction (towards or away) relative to TraceTek alarm module.
- Arrange excess pull rope by coiling around the riser pipe and taping in place.
- Cover conduit ends to maintain cleanliness within conduit. Use a plastic bag taped in place, or stuff a clean rag into conduit end.

3a

Install sensing cable in accordance with the leak detection layout plan.

Planning the cable pull:

- Verify that each end is terminated in a rope overbraid loop. Identify which end of the cable (Pin or Socket) is on the outside of the reel by examining the label near the overbraid loop.
- Attach the pull rope to the rope overbraid loop only after planning the direction of the cable pull based on which cable end is on the outside of the reel. **Note the PIN connector end of cable is always oriented towards the TraceTek alarm module.**
- If PIN connector end is on the outside of reel, pull cable into conduit towards the TraceTek alarm module.
- If SOCKET connector end is on the outside of reel, pull cable into conduit away from the TraceTek alarm module.

Common mistakes include pulling the cable into the wrong conduit, and pulling the wrong end of cable into the conduit.

Before pulling the cable into any conduit, verify that correct conduit is being used. Good conduit installations will use a strategy to mark conduits. Check with project supervisors if any doubt exists as to how the conduit is labeled. Errors in conduit identification and cable orientation can result in compromised cable quality.

TT5000-HS and TT5001-HS Sensing Cable Installation Instructions

3b**Attach the Kellems grip (if necessary):**

- For TT500X-HS bulk cable, you may need to use a Kellems grip to perform the cable pull when the rope overbraid loop is not available.
- Make sure the end of the sensing cable has been properly prepared.
- The end of TT500X-HS sensing cable should be sealed with heat shrink tubing, and the end of the rope braid should be taped to form a tapered end.

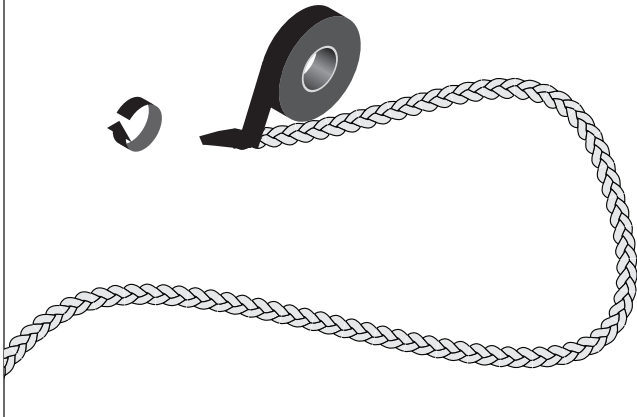
**3c**

- Insert the end of the rope braid as far as possible into the cage end of the Kellems grip.

**3d**

- Tightly wrap electrical tape over last 1 inch of the Kellems grip cage, and also over 1 inch of the rope braid. Make a smooth transition with the tape. The tape is necessary to prevent the Kellems grip cage from releasing the cable in the event of a backwards pull.

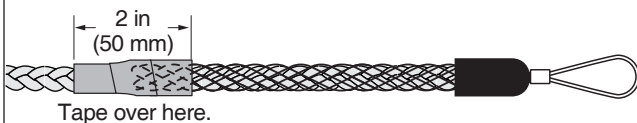
**4****Pulling the cable:**

- TT500X-HS sensing cable is sensitive to pressure from such things as pinches or tight corners. Cable stress, binding and kinking can result in cable damage and potential false leak detection signals. Take care during installation to maintain cable integrity in order to promote a successful project.
- Two people are needed to manage the pull rope. One person is on each end of the end pull rope, and each person must be able to communicate with the other in case of problems during the pull.
- Before pulling the cable into the conduit, identify the correct pull rope. If there is more than one section of pull rope at this access point, the person feeding the cable can lightly tug the pull rope, while the person on the pulling end confirms they feel the tension.
(A common mistake results from the wrong rope end being pulled, and the other end of the pull rope disappearing into the conduit).

NOTE: BE careful not to lose the rope into the access point conduit. It can be time consuming and expensive to recover a pull rope lost into the conduit.

- Confirm the pull rope moves easily. Slow and steady pulling is recommended to promote an easier installation which results in reduced stress on the cable. The person feeding the cable into the conduit needs to provide continual slack to reduce stress on the cable. The person feeding the cable must be able to communicate problems (such as snags or twisted cable) to the person pulling, before the sensing cable is subjected to excessive stress.
- As you pull, coil the pull rope by hand and keep the pull rope out of the dirt by placing it on cardboard or plastic sheeting.
- If the pull rope becomes stuck, do not increase pull force—instead pull the rope in opposite direction for a short distance, then try repulling in original direction with normal force.
- Finish the cable pull by extending the TT500X-HS-MC (with factory installed connectors) or TT5000-HS-HYB-HSE (with factory installed end termination) cable at least 1 foot beyond top of the access point conduit riser.
- For TT500X-HS (bulk sensing cable without connectors) cable, extend at least 2 feet beyond top of the access point conduit riser. The extra length is necessary due to connectorization requirements.
- Secure excess pull rope by coiling around the riser pipe and taping in place.
- Cover conduit ends to maintain cleanliness within conduit. Use a plastic bag taped in place, or stuff a clean rag into conduit end.

TT5000-HS and TT5001-HS Sensing Cable Installation Instructions

Installation

5

Expose the sealed end of the cable, see illustrations A, B and C below

- For connectorized cable (TT500X-HS-MC), remove the heat shrink tubing from the sealed end, then remove the attached end termination to access the connectorized cable end.
- **Test each length of connectorized sensing cable after pulling into conduit and before attaching it to cable already installed. Confirm that the sensing cable is clean and intact by following the Sensing Cable Test Procedure, described later in this document.**

Connectorization procedure for bulk cable

- Bulk (unconnectorized) cable is usually connectorized after pulling into conduit. Use connector kit TT5000-HUV-CK-MC-M/F for TT500X-HS sensing cable. Refer to TraceTek document H54830 for detailed instructions regarding connectorization procedures. If bulk cable is cut and connectors will not be immediately installed, use shrink tubing or carefully tape the cable ends to protect cable integrity (water/physical damage). If water enters cable ends, the cable will be compromised and may have to be replaced.

5a

- Grasp rope braid about 1 in. (25 mm) behind the taped end near the looped end of the pull rope. Feel for the sealed end of the sensor cable beneath the rope braid. Bend the rope braid to a 90 degree angle and locate sealed end of the sensor cable.

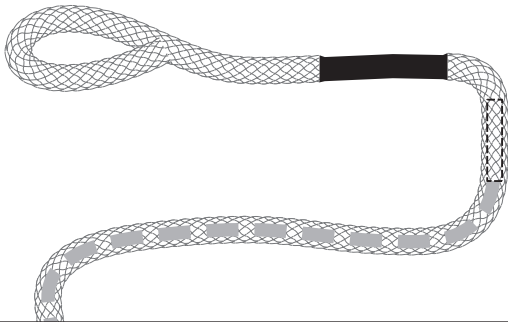

5b

- Spread the rope braid fibers apart to expose the sealed end of the sensor cable.

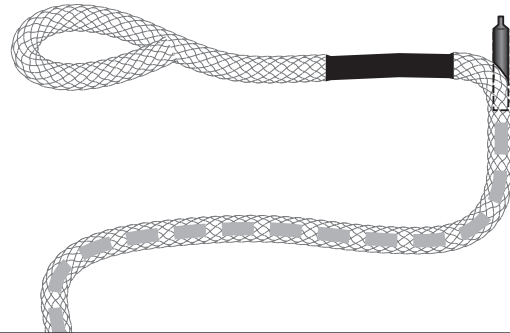

5c

- Grasp the sealed end and pull about 12 inches (30 cm) of sensor cable out while holding the rope braid in place.
- Tape the rope braid to sensor cable to prevent the rope from springing back.

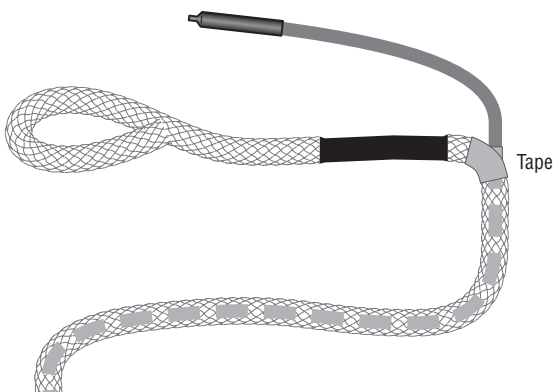

6

Prior to installing a new length of sensor cable, slide the unlabeled shrink tube (from connector kit) onto the cable. Connect the sensing cable to the cable circuit (lengths of sensing cable connected in series) previously installed.

- Mark the connector position on the layout plan.
- Install TraceTek mapping tag (TT-TAG).
- Note: As an extra precaution on large installations, periodically test the entire cable circuit to confirm that all installed sensing cable is still clean and intact.
- Unplug the end termination and connect it to the next length of sensing cable to be installed.

Repeat the installation sequence for each length of cable.

7

Complete the system

1. Install other TraceTek components (such as Modular Branching Connectors, Weighted Lengths, and Modular Jumper Cables) as called for in the system layout. Complete the sensing circuit.

Note: All components of the system have male or female metal connectors or both. The male connectors are oriented toward the instrument panel. As new sections of cable are added to the main leg or branch, each newly added section should end with an open female connector. The end of each branch or main leg is terminated with a male end termination.

2. Test the sensing circuit (or portions of it) to confirm that the sensing cable is clean and intact. Follow the Sensing Cable Test Procedure.
3. Locate the unlabeled heat shrink tubing segment (delivered along with the TT500X-HS connectorized cable, or as part of the TT5000-HUV-CK-MC-M/F connector kit.) Install the heat shrink tube as environmental seal over all mated male/female (pin/socket) connections.
 - Center the unlabeled shrink tube over the pin/socket connection. Heat shrink the tube over the connection, beginning in the center and shrinking towards the ends until the tube fully conforms to the shape of the connection and adhesive flows from each end of the tube.

CAUTION: Burn Hazard

Do not get hot adhesive on your bare skin. The hot adhesive will burn your skin.

- Avoid overheating the thin wall unlabeled shrink tubing. The thin wall tubing requires less heat than the SCT cable shrink tubing.

- **Let the entire connector area cool before handling the cable.**

Note: Do not leave connector open to environment. If the connector becomes wet or contaminated, it will need to be replaced.

Note: When arranging any TT500X-HS cables do not use a bend radius less than 2 in. (51 mm).

Note: If a heat-shrinkable tube must be removed (for example, for cable testing), refer to Oversleeve Removal Instructions (H54258).

4. Connect the sensing circuit to the TraceTek alarm module and activate the system as soon as is practical. Use the alarm module to monitor for events during the final stages of construction.

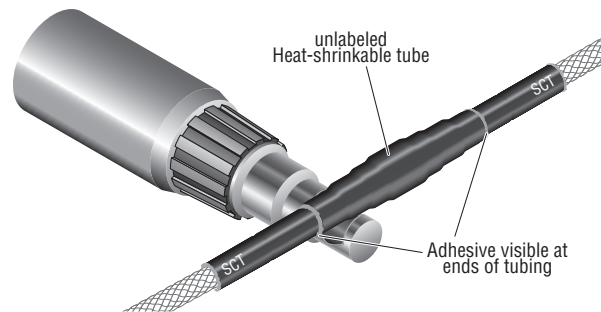
**WARNING:**

Fire Hazard. Heat guns and flameless heating tools can cause fire or explosion in hazardous areas. Be sure there are no flammable materials or vapors in the area before using these tools. Follow all site safety guidelines when working in hazardous areas.

Component approvals and performance are based on the use of specified parts only.

CAUTION:

Health Hazard. Overheating heat-shrinkable tubing will produce fumes that may cause irritation. Use adequate ventilation and avoid charring or burning. Consult MSDS RAY3122 for further information.

24-hour emergency telephone:
CHEMTREC (800) 424-9300.

Non-emergency health and safety information:
(800) 545-6258.

8

Take precautions if installation is incomplete at end of work day.**At the end of the work day:**

- Ensure that there are no exposed connectors. Each sensing cable should be connected to a Modular Leader Cable (TT-MLC-MC), Modular End Termination (TT-MET-MC), and/or other sensing cables; check both ends of the cable.
- Test and record the condition of installed sensing cable following the Sensing Cable Test Procedure.
- If practical, connect the installed sensing cable to the TraceTek alarm module. Test the system and put it in operation following the alarm module installation instructions.

At the beginning of the next work day:

- Check that the installed sensing cable is clean and intact following the Sensing Cable Test Procedure. Compare the results with those obtained at the end of the previous work day. If necessary, investigate and correct problems before proceeding.

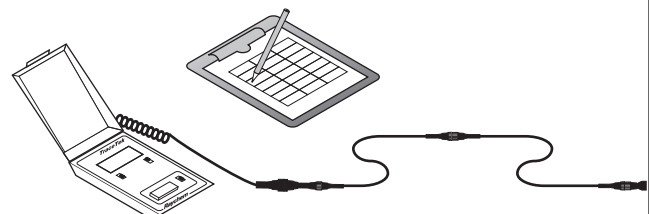
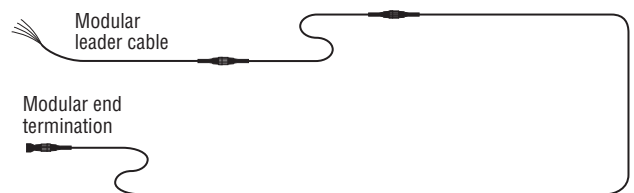

TT5000-HS and TT5001-HS Sensing Cable Installation Instructions

Sensing Cable Test Procedure

Method with TraceTek Portable Test Box (TT-PTB-1000)

1. Ensure the end termination is connected to the sensing cable. If checking several lengths of sensing cable in series (a cable string), ensure they are all connected.
2. Connect the PTB to the sensing cable(s) using its adapter, as illustrated.
3. **Verify that the sensing cable is intact;** follow the operating instructions printed inside the lid of the PTB itself. If a cable or connection is broken, the PTB illuminates its LED indicating "cable break," and displays a "1" in the leftmost position of its LCD display. If the cable string is intact, the PTB measures the system length.
 - If the cable string is not intact, apply this test procedure to segments of the system to identify the open connection or damaged modular length.
 - **Note:** If a heat-shrink tube must be removed to access a connector, refer to Oversleeve Removal Instructions (H54258).
4. **Check the condition of the sensing cable(s),** again following the PTB operating instructions. If the sensing cables are clean and free of contamination, the current measured should be 0 μ A. If the reading exceeds 10 μ A, use the PTB to locate the liquid or contamination and take appropriate corrective action.

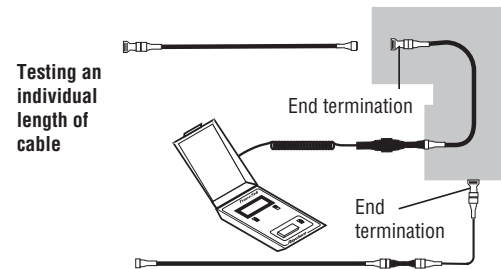
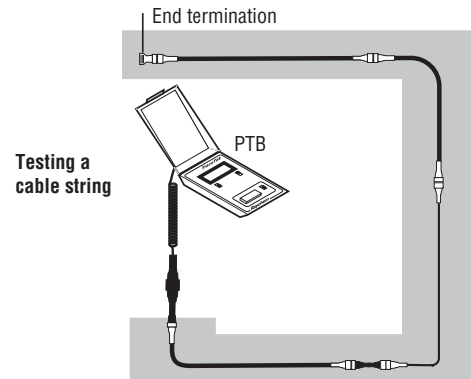

Method with Ohmmeter

1. Ensure the end termination is connected to the sensing cable. If checking several lengths of sensing cable in series (a cable string), ensure they are all connected.
2. Connect a Modular Leader Cable (TT-MLC-MC) to the sensing cable.
3. **Verify that the sensing cable is intact:**
 - Loop 1: Measure the resistance between the yellow and black wires of the leader cable as illustrated.
 - Loop 2: Measure the resistance between the red and green wires of the leader cable.

The readings should roughly equal a multiple of the length of sensing cable:
4.0 times the length of sensing cable (in feet), or 13.1 times the length of sensing cable (in meters).

Example: 4.0 x 50 ft of cable = 200 Ω
13.1 x 15 m of cable = 197 Ω

In addition, the resistance of the two loops should be within 5 percent of each other.

If the cable string is not intact, apply this test procedure to individual segments of the system to identify the open connection or damaged modular length.

Note: If a heat-shrink tube must be removed to access a connector, refer to Oversleeve Removal Instructions (H54258).
4. **Check the condition of the sensing cable.** Measure the resistance between the black and green wires of the leader cable.
 - If the reading is below 20 megohms, apply this test procedure to individual segments of the system to identify the modular sensing cable length(s) affected, locate the damage or contamination, and take appropriate corrective action.

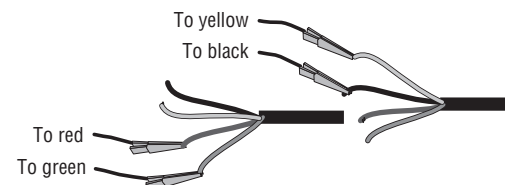
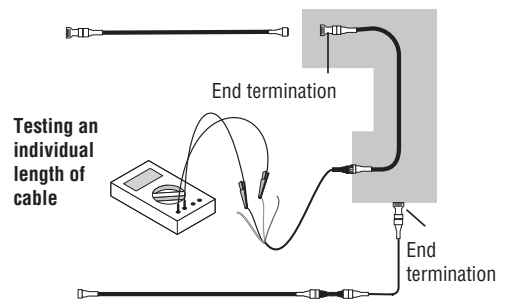
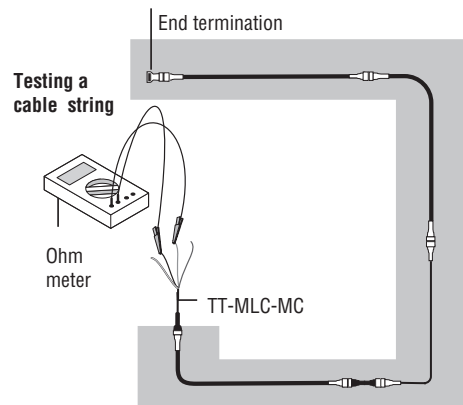

TT5000-HS and TT5001-HS Sensing Cable Installation Instructions

Complete System Connections and Layout

- A. TT500X-HS is available in bulkform, cut to length in the field and joined using connector kits - or it can be obtained in standard or custom cut lengths with connectors attached in the factory. Each cable has a female metal connector on one end and a male metal connector on the opposite end. Cable sections plug together like extension cords.
- B. (Optional) A branch connector (TT-MBC-MC-TW) is used to connect and branch "T" lines. The branch connector has one male connector and two female connectors. For mapping purposes, the cable connected to the center leg of the branch connector will be counted first, then the distance measurements will continue from the second female connector and continue along the rest of the system. A dead band of 16 ft (5 m) is inserted at the beginning of each branch to avoid any location ambiguity.
- C. (Optional) It is permissible to have multiple sub-branches as needed to fully trace the pipe system.
- D. Install an end termination (TT-MET-MC) at the end of the main line and each branch line. (Note: A good check on the system design and bill of materials is that the total number of end terminations installed in the system should equal the number of branch connectors plus one).
- E. (Optional) Install jumper cables (TT-MJC-xx-MC-BLK) as needed if they are to connect sensing cable sections in separate areas. Jumper cable is available in various pre-cut and terminated lengths and is also available in bulk form for long distance runs between the sensor cable and alarm module location.
- F. Install a leader cable (TT-MLC-MC-BLK) between the sensor cable and the alarm module location. The factory standard length of leader cable is 12 ft (4 m). It has a female metal connector on one end and four tinned leads on the opposite end for connection at the alarm module terminal block. In some installations the distance between the alarm module and the start of the sensor cable run will be much greater than 12 feet. In those cases a simple solution is to purchase a jumper cable of sufficient length, then cut off and discard the male connector and any extra cable. Bulk jumper cable and splicing kits are also available for lengths that exceed the longest available standard jumper cable.
- G. Use fastening straps to neatly coil and secure any excess sensor cable, jumper cable, branch connectors, etc.

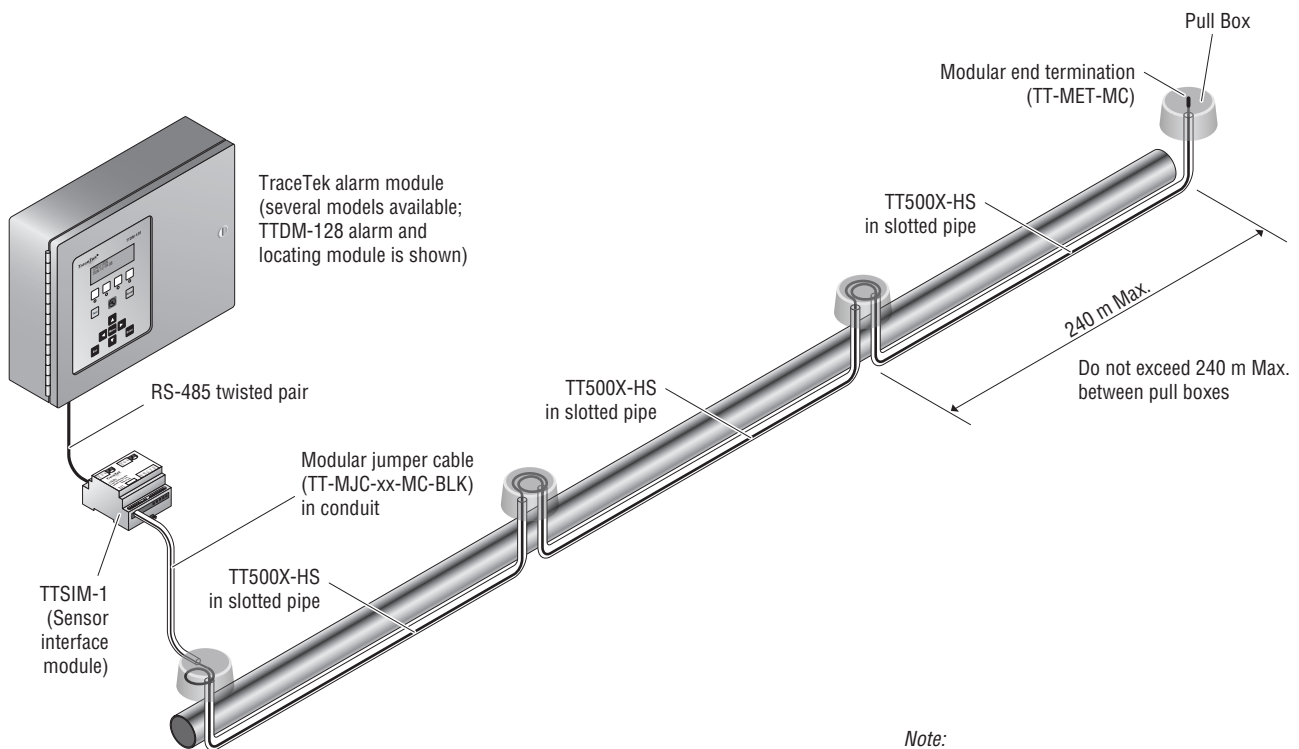

Note:

- Drawing not to scale.
- Not shown: heat-shrinkable tube to cover each connection.

TT5000-HS and TT5001-HS Sensing Cable Installation Instructions

Initial Power-up and Test

Connect the cable to the alarm module and test the system.

- For direct buried long line underground leak detection applications, TraceTek requires use of TTSIM-1. TTSIM-1 can be used as standalone unit or in conjunction with TTDM-128.
- Apply power to the TraceTek instrument and look for a “Normal” indication.
 - On TTSIM-1, Normal Condition is indicated by a green LED and a momentary flash of the RED LED every 5 seconds.
 - On TTDM-128 the alpha-numeric display will indicate a channel number and display the words SYSTEM NORMAL.
- If the Yellow LED is on in any of these instruments or the words “Cable Break” or “Loop Break” is displayed, then the cable system must be inspected for loose connections, missing end terminations until the cable continuity is established and the “Normal” condition is achieved.
- Leak testing can be done with a mapping cap (TT-MAPPING CAP-MC) or by bending the sensor cable tightly between fingers. The MAPPING CAP simulates a leak at the location where it is installed in the system.
 - For TTSIM-1 a red LED will indicate that the simulated LEAK has been detected.
 - For TTDM-128 a leak location will be displayed in feet or meters (as selected) in addition to the red LED indication
- For larger piping systems with TTDM-128 or TTSIM-1, the MAPPING CAP should be moved sequentially to each accessible connector. Record the distance displayed on the as-built drawings. This will become the basis for the System Map.
- Create a System Map showing where sensing cables and alarm modules have been installed. The System Map will include the beginning and end of sensing cables, and location of any connections. If using locating alarm modules, the System Map should include distance readings at significant landmarks (beginning and end of system, changes of direction, branches, valves, low points, etc.).

Note: Do not use fuel to test the TT5000-HS cable. Do not use solvent to test the TT5001-HS cable. The TT500X-HS cable is not resettable after exposure. Leak testing should be done, by bending sensor cable tightly between fingers, or with a mapping cap (TT-MAPPING CAP-MC). The TT-MAPPING CAP-MC simulates a leak at the location where it is installed in the system.

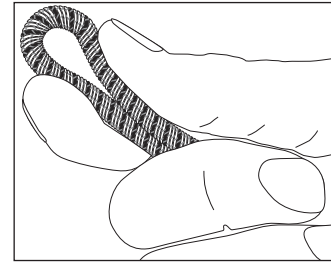

Manual leak testing

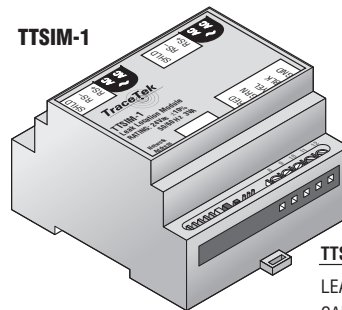

TTSIM-1 Indications:

LEAK	Red
CABLE BREAK	Flashing yellow
SERVICE	Flashing yellow
POWER LED	Green

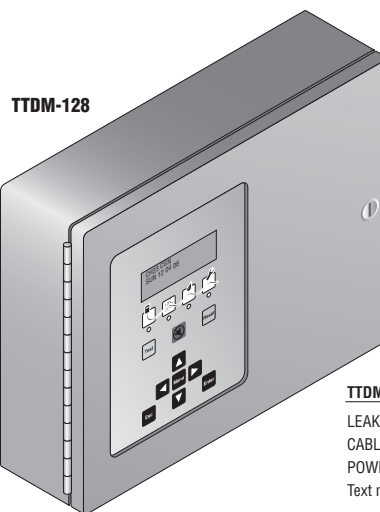

TTDM-128 Indications:

LEAK	Red
CABLE BREAK	Yellow
POWER LED	Green
Text message in 4x20 display	

TT5000-HS and TT5001-HS Sensing Cable Installation Instructions

Troubleshooting

Symptom	Possible Cause and Correction
Green LED not visible on TraceTek instrument	System is not powered. Check power wiring. Check circuit breakers that may have been tripped. On TTDM-128 check fuse and replace if necessary.
Leak alarm (TTDM-128 message and red LED) (TTSIM-1 Red LED ON)	<p>This is an indication of a LEAK event.</p> <p>For leak locating modules (TTDM-128): Using leak distance indication and System Map as a guide, investigate system condition, work to locate and repair leak.</p> <p>For non-locating modules: Work to locate and repair the leak. (If your system is constructed with multiple sensor cable segments, using an end termination (TT-MET-MC) to break the system into sections can help in locating the leak. Work outward from the alarm module using the end termination to establish a temporary end of the circuit, then sequentially move outward adding one cable segment at a time).</p> <p>TT500X-HS cannot be reset like other TraceTek cables. Once the cable has been exposed to fuel (for TT5000-HS) or solvent (for TT5001-HS) it must be replaced. Damaged cable must be cut out of the system and replacement cable must be installed using factory standard lengths or sections of bulk cable and connector kits.</p> <p>In the event of a leak, examine the metal connectors on the sensing cable for possible corrosion. Also examine the conduit and soil in the leak vicinity for residual contamination. Replace any damaged components; thoroughly clean up all leaked liquid to eliminate the risk of another sensor cable alarm from residual contamination.</p> <p>Note: When the Service Req'd or SERVICE condition exists (Yellow LED), leak location accuracy is reduced for a new leak.</p>
Flashing yellow LED on TTSIM-1	<p>Could be cable break or service indication. Refer to alarm module instructions for more information.</p> <p>For Cable break indication: Check for loose connectors, missing end terminations, broken jumper wires or physical damage to the cable. Repair or replace cable if necessary. The TT-MET-MC end termination can be used to isolate a damaged section by working outward from the instrument using the end termination to establish a temporary end of the circuit then sequentially moving outward adding one cable segment at a time.</p>
"SERVICE Req'd" message (TTDM-128 Only)	This is an early warning message from the TTDM-128 panel indicating there is current leakage, but not yet to the level that constitutes a leak. The TTDM-128 panel may display a location in square brackets. If a location is displayed it should be investigated for possible sources of kinks or pinches. The square brackets indicate that the leak signal is not strong enough for an accurate location calculation, and may include some error.
Red LED fails to turn off after leak is repaired, and leak alarm reset attempted	Examine cable for additional damage or leaks.
Leak location seems inaccurate in actual leak situation	More than one leak may be present or the cable may be wetted in several locations. If the system is monitored by a TTDM-128, check the event history to see if there is an earlier indication of a nearby leak or a SERVICE NEEDED message. If necessary use the end termination to break the system into smaller segments and work outward to isolate each leak location in multiple leak scenarios.
Leak locations seem inaccurate or unstable during mapping tests	Make sure that the simulated leak produced by tightly bending the sensor cable or use of TT-MAPPING CAP-MC is kept in place for at least 30 seconds. The location circuitry in the instruments require a steady leak location in order to compute an accurate distance. Removing the simulated leak too quickly induces a random error.

Tyco and TraceTek are registered and/or unregistered trademarks of Tyco Thermal Controls or its affiliates. All other trademarks are the property of their respective owners.

Worldwide Headquarters
Tyco Thermal Controls
 7433 Harwin Drive
 Houston, TX 77036
 USA
 Tel 800-545-6258
 Tel 650-216-1526
 Fax 800-527-5703
 Fax 650-474-7215
 info@tracetek.com
 www.tracetek.com

Important: All information, including illustrations, is believed to be reliable. Users, however, should independently evaluate the suitability of each product for their particular application. Tyco Thermal Controls makes no warranties as to the accuracy or completeness of the information, and disclaims any liability regarding its use. Tyco Thermal Controls' only obligations are those in the Tyco Thermal Controls Standard Terms and Conditions of Sale for this product, and in no case will Tyco Thermal Controls or its distributors be liable for any incidental, indirect, or consequential damages arising from the sale, resale, use, or misuse of the product. Specifications are subject to change without notice. In addition, Tyco Thermal Controls reserves the right to make changes—without notification to Buyer—to processing or materials that do not affect compliance with any applicable specification.