

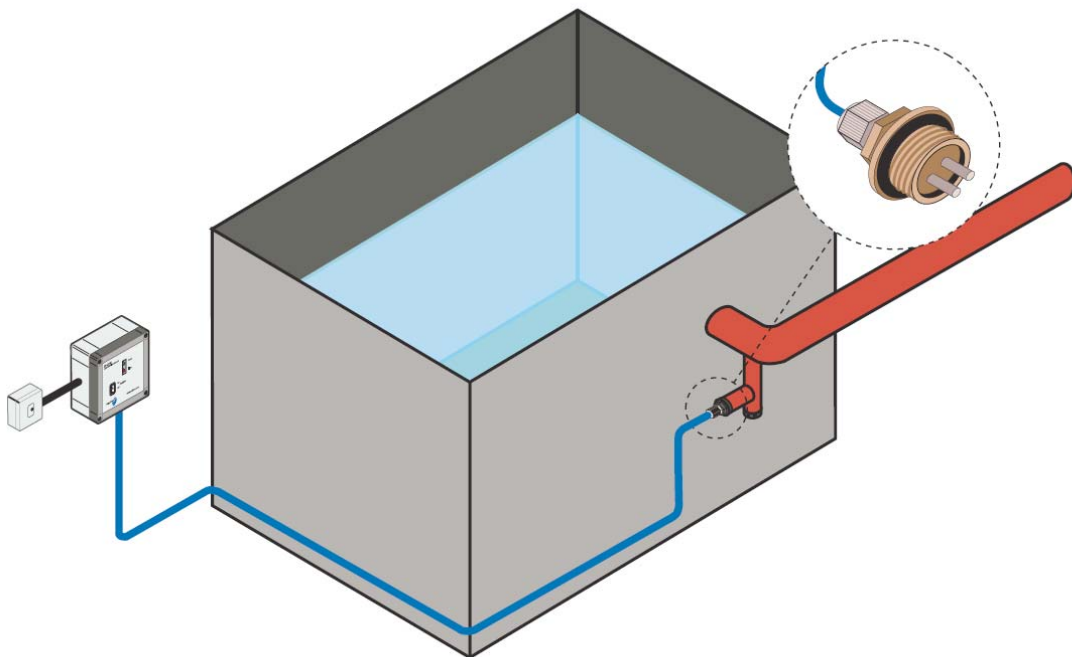

This illustration shows the use of the AquiTron™ AT-LDM (Leak Detection module) linked to an immersion sensor screwed into the overflow pipe for a water storage tank or a sprinkler water storage tank.

The same equipment can be used to detect water flowing in any overflow or drainage pipe which would under normal condition be dry.



Important: All information, including illustrations, is believed to be reliable. Users, however, should independently evaluate the suitability of each product for their application. Aquilar Limited makes no warranty as to the accuracy or completeness of the information, and disclaims any liability regarding its use. The only obligations of Aquilar Limited are those in the Aquilar Standard Terms and Conditions of Sale for this product, and in no case will Aquilar Limited be liable for any incidental, indirect, or consequential damages arising from the sale, resale, use or misuse of the product. Specifications are subject to change without notice. In addition, Aquilar Limited reserves the right to make changes – without notification to Buyer – to processing or materials that do not affect compliance with any applicable specification.

Aquilar is a trademark of Aquilar Limited  
AquiTron is a trademark of AquiTron Limited

### Description

The AquiTron™ AT- LDM offers a low cost option for liquid leak detection. It is designed for use with all TraceTek sensing cables, AquiTron™ probes and other sensing devices to detect leaks. The AT-LDM provides visual indication when a leak has occurred and has relay contacts to connect to other external alarm equipment. An option is available with an audible alarm.

Each module comes in two forms; either with DIN rail mounting frame or polycarbonate enclosure together with comprehensive installation instructions.

### Simple Operation

Two LED's to indicate the operating status of the unit:  
POWER – alarm unit power (green)  
LEAK – liquid detected (red)

### Application

Primarily designed for small area detection in locations such as Tea Points, Kitchens, Bunded area's and Drip Trays, or alternatively these units can be used with the AquiTron™ AT-RWS-1 Rain Sensor.

Because of their compact size these modules can normally be easily incorporated into OEM equipment or outstation enclosures thus saving the cost of a dedicated enclosure.

Modules can be sited close to the area to be monitored or mounted up to 200 metres away in control equipment.

AT-LDM-SM housed in a polycarbonate enclosure



AT-LDM & AT-LDM-S open chassis, DIN rail mounting



### Technical Information

Sensing cable compatibility	All TraceTek adapted sensing cable (TT1000, 3000, 5000, 5001 and 7000 )
Detection Probes	Water detection probes, optical oil sensors, float switches and immersion sensors
Maximum length of sensing cable	45 metres (150 ft)
	Combination of any 10 AquiTron™ probes
Enclosed version	Polycarbonate; smoked transparent lid, base & grey base; IP 66
Operating Conditions (PCB)	-10 to +50 °C, 0% to 90% non-condensing
Power supply	Two versions: 24V ac/dc & 230Vac (ac 50/60Hz)
Power consumption	50 mA @ 24V ac/dc and 11mA @ 230Vac
Relay Output	Volt free relay contacts activated by leak SPDT (NC/COM & NO)
Relay Rating	5 A at 250 Vac/24 Vdc
Status LED	Power (Green), Leak (Red)
Audible Alarm	85dB 10cm (where fitted)
Dimensions	Open chassis: 77mm x 112mm x 45mm Enclosed: 130mm x 130mm x 75mm
Weight	Open chassis: 82g ~ 24V version & 248g ~ 230V version Enclosed: 660g

## Approvals

Electromagnetic compatibility (EMC)



---

Ordering information	Catalogue number	4200	AT-LDM	Open Chassis: 24Vac
		4205	AT-LDM-S	Open Chassis: 24Vac with sounder
		4210	AT-LDM	Open Chassis: 230Vac
		4215	AT-LDM-S	Open Chassis: 230Vac with sounder
		4220	AT-LDM-SM	Enclosed: 230Vac with sounder & mute

---

## Operational Notes

All Modules are Auto Reset and the relay contacts will remain activated as long as the sensor is wet.

On Modules with sounders fitted the sounder can be temporarily silenced by removing a link on the open chassis version or operating the switch on the enclosed versions

---

---

Important: All information, including illustrations, is believed to be reliable. Users, however, should independently evaluate the suitability of each product for their application. Aquilar Limited makes no warranty as to the accuracy or completeness of the information, and disclaims any liability regarding its use. The only obligations of Aquilar Limited are those in the Aquilar Standard Terms and Conditions of Sale for this product, and in no case will Aquilar Limited be liable for any incidental, indirect, or consequential damages arising from the sale, resale, use or misuse of the product. Specifications are subject to change without notice. In addition, Aquilar Limited reserves the right to make changes – without notification to Buyer – to processing or materials that do not affect compliance with any applicable specification.

Aquilar is a trademark of Aquilar Limited  
AquiTron is a trademark of AquiTron Limited  
TraceTek is a trademark of Tyco Thermal Controls.

### Aquilar Limited

Dial Post Court, Horsham Road,  
Rusper, West Sussex RH12 4QX. UK  
Tel: + 44 (0) 1293 871874  
Fax: +44 (0) 8707 940 320

E-mail: [info@aquilar.co.uk](mailto:info@aquilar.co.uk)  
[www.aquilar.co.uk](http://www.aquilar.co.uk)

Master TraceTek Distributor UK & Ireland for  
**Raychem® TraceTek®**  
Water, Fuel and Chemical Leak Detection

### Description

The immersion sensor has been designed for use with the TraceTek and AquiTron™ leak detection systems and is fully compatible with all TT1000 system components.

The probe has been designed for seamless integration into TraceTek and AquiTron™ water detection systems, either with or without sensor cable, to provide a truly versatile sensor system.

For distributed applications, up to 100 probes may be interconnected by a single jumper cable (daisy chain) and monitored for leak location utilising either a TTDM-PLUS or TTSIM-1/1A alarm and locating modules providing leak location in either metres, feet or zones. The AT-SZA and MZA panels provide a single or multi zone indication. (see panel data sheets for maximum probe quantities).

### Application

Applications for the immersion sensor include: overflow pipes for boilers, heating systems, unvented hot water cylinders, blow down pipes, drainage, tank level control and applications using double containment pipe systems.

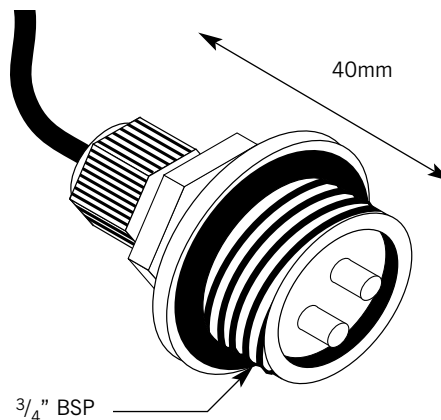
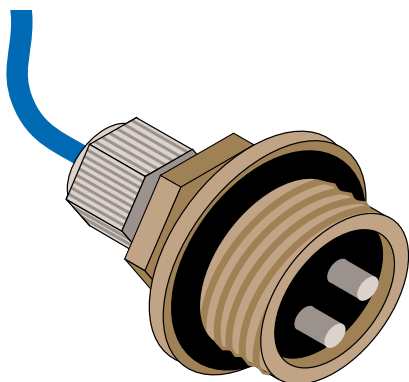

### Technical Information

Type	AT-600A
Brass body	3/4" (inches) BSP Male Thread
Maximum operating temperature	100 deg C
Probe tips	Coated Stainless Steel
Mounting	Vertical and horizontal to suit application
Fly lead connection	2 metres
Fixing	Screw the brass body into a female 3/4" BSP fitting and seal with an 'O' ring or PTFE/sealing tape
Draining	Unscrew the brass body, dry and refit

### Ordering Information

Catalogue number	2435 AT-600A Immersion-flow sensor
------------------	------------------------------------

### Optional

Alternative brass body threads i.e. metric available to order

**Important:** All information, including illustrations, is believed to be reliable. Users, however, should independently evaluate the suitability of each product for their application. Aquilar Limited makes no warranty as to the accuracy or completeness of the information, and disclaims any liability regarding its use. The only obligations of Aquilar Limited are those in the Aquilar Standard Terms and Conditions of Sale for this product, and in no case will Aquilar Limited be liable for any incidental, indirect, or consequential damages arising from the sale, resale, use or misuse of the product. Specifications are subject to change without notice. In addition, Aquilar Limited reserves the right to make changes - without notification to Buyer - to processing or materials that do not affect compliance with any applicable specification.

AquiTron is a trademark of AquiTron Limited  
 Aquilar is a trademark of Aquilar Limited  
 TraceTek is a trademark of Tyco Thermal Controls

**Aquilar Limited**  
 Dial Post Court, Horsham Road,  
 Rusper, West Sussex RH12 4QX. UK  
 Tel: + 44 (0) 1293 871874  
 Fax: +44 (0) 1293 871717

E-mail: [info@aquilar.co.uk](mailto:info@aquilar.co.uk)  
[www.aquilar.co.uk](http://www.aquilar.co.uk)

Master TraceTek Distributor UK & Ireland for  
**Raychem® TraceTek®**  
 Water, Fuel and Chemical Leak Detection

