

Field Installed Connectors for TraceTek® 5000 Bulk Cable

Installation Instructions

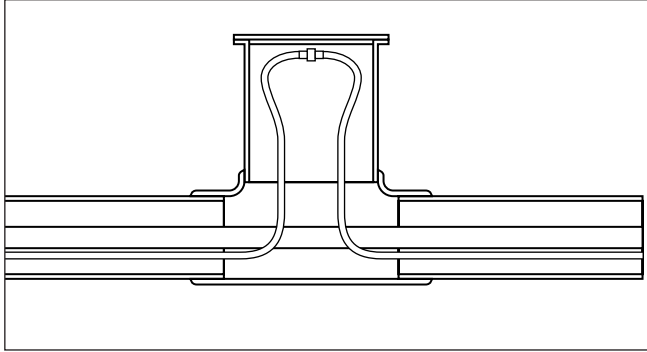

Hazardous Locations:
For use with intrinsically
safe sensor circuits for
Class I, Div. 1, Groups A, B, C, D



Description

This kit contains parts to install 5 pairs of connectors onto TT5000 sensing cable.

Tools Required

- Needle nose pliers
- Flameless heating tool (Ultratorch 200)
- High impedance ohm-meter (Fluke 87 or equivalent; meter must be capable of measuring to at least 20 MEGΩ)
- Greenlee strippers (1917 or 1918)
- Razor blade or utility knife
- Small pair of wire cutters
- 3/4" masking tape

Notes

- Do not substitute kit parts.
- Do not use an open flame heating tool.
- The pin connector should always be installed on the cable end pointed towards the alarm and locator module.
- Use with TT5000 Bulk Cable only. This kit is not compatible with other TraceTek Cables.

Kit Contents

Item	Qty	Description
A	5	TT-CK-MC-M pin connectors w/spinner ring
B	5	TT-CK-MC-F socket connectors
C	12	Kynar® spacers (2 extra)
D	65	SolderSleeve® splices (5 extra)
E	11	Striped heat-shrinkable tubing (2-1/2" x 3/4") (1 extra)
F	11	Heat-shrinkable tubing (2" x 3/4") (1 extra)
G	1	TT-MET-MC Pin end termination
H	1	TT-FET-MC Socket end termination
I	1	Pin and socket test tool

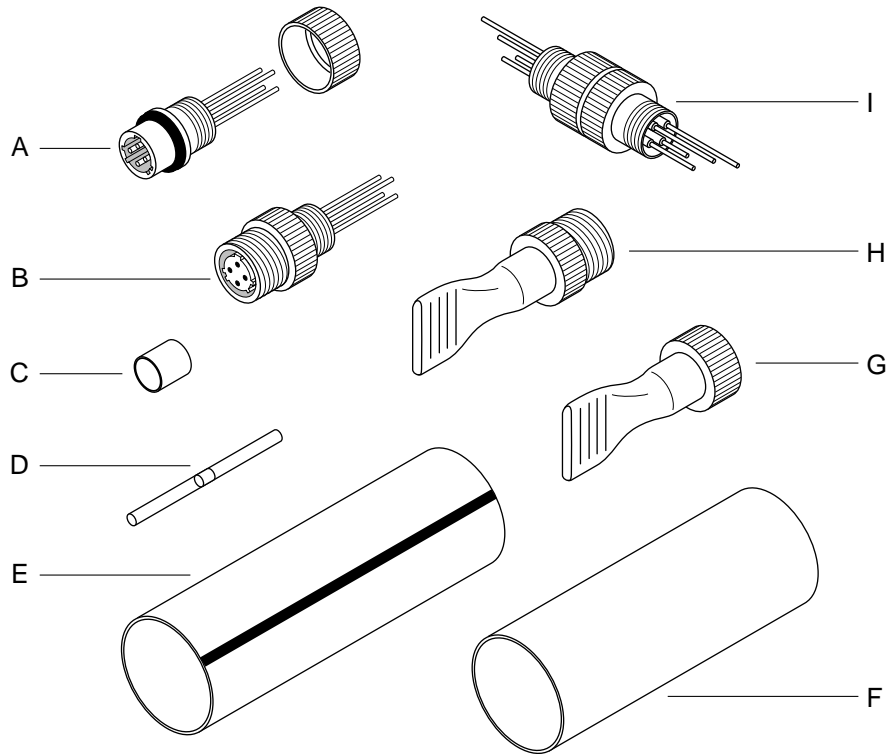

⚠ WARNING: Fire Hazard. Heat guns and flameless heating tools can cause fire or explosion in hazardous areas. Be sure there are no flammable materials or vapors in the area before using these tools. Follow all site safety guidelines when working in hazardous areas.

⚠ WARNING: Overheating heat-shrinkable tubing or solder sleeves will produce fumes that may cause irritation. Use adequate ventilation and avoid charring or burning. Consult MSDS RAY/3122 and RAY/5104 for further information.

**TT-5000-CK-MC-M/F Field Installed Connectors for TT5000 Bulk Cable
Installation Instructions**

1

12" min.

- Ensure sufficient sensing cable to make a service loop at the access point.

2

Fold end of tape back on itself for easy removal

1 1/2"

- Wrap 3/4" masking tape 1 1/2" from the end of the cable (see ruler at side of the page).
- Wrap a second piece adjacent to the first.
- Fold the ends of each piece of tape for easy removal.

3

Do not slit here

1"

- Slit 1" of the outer braid lengthwise.
- Remove severed strands.
- Twist and push the remaining braid back to the tape.
- Use cutters to cut off braid strands at the tape.

4

End view of razorblade

1"

Do not cut through the black jacket

- Very lightly score all the way around the black jacket with a razor blade or utility knife.
- Remove the 1" jacket section by twisting clockwise and pulling.

5

- Bend the core sharply in all directions to flare the black jacket and inspect the wires for damage at the cut.

Part C

- Slip the Kynar spacer over the core bundle and under the jacket.
- **Do not fold or tear the jacket.**

Kynar spacer should protrude $\approx 1/32"$

- Trim away any jacket shards that may be present.

6

- Unbraid the core wires.
- Cut off the 3 white wires and 4 blue braid fibers.
- **Avoid nicking the remaining wires.**

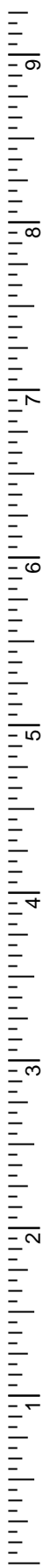

**TT-5000-CK-MC-M/F Field Installed Connectors for TT5000 Bulk Cable
Installation Instructions**

7

- Straighten the remaining wires by pulling slightly and flexing.
- Trim all 4 wires to 1" long. To avoid breaking the wires, strip the insulation in small sections until 3/4" has been removed. Use the 26 AWG (0.15mm²) slot for the black wires and the 22 AWG (0.4mm²) slot for the red and yellow wires.

Try not to break wire strands while stripping.

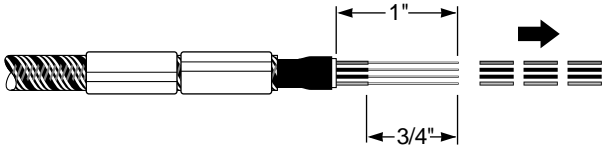

8

Do not clip onto the black jacket.

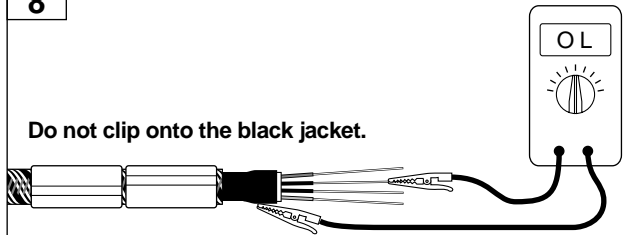

- Set the ohmmeter to its highest resistance scale. Measure the resistance between the black wires and jacket as follows: Lightly touch one ohmmeter lead to the black jacket. Clip the other lead to each of the black wires (one at a time). If both measurements are over 20 MEGΩ (meter may read: ∞, O.L., etc.), Proceed to the next step. If either measurement is less than 20 MEGΩ, check that the jacket does not touch the black wire at either cable end. If no shorts can be found, do not use the cable section. Contact Raychem for help.

9

For either connector type, the red and yellow wires need to be pretinned.

- Twist together any loose strands of the red or yellow wires.
- Slide a SolderSleeve® splice (part D) onto the red or yellow wire.
- Heat the solder band in the center of the splice until it flows onto the bare wire.
- Immediately remove the splice from the wire.
- Repeat the process with the other stranded wire.
- Discard the used solder sleeves.

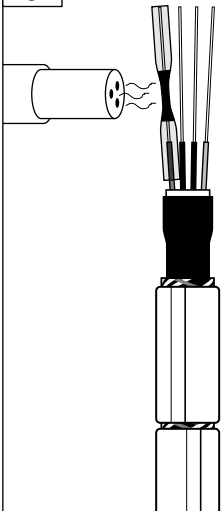

10

- For the pin connector (part A) only, slip the spinner ring, small hole first, onto the cable.

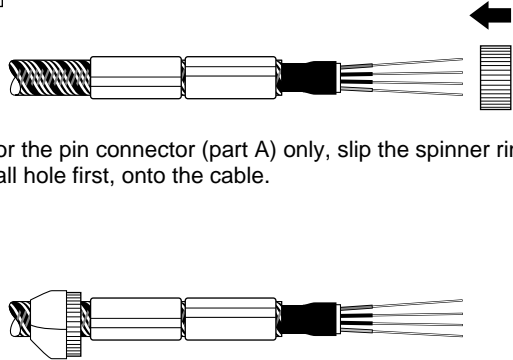

- Tape the spinner to the cable to avoid losing it into the access point.

11

- Slide 4 new SolderSleeve® splices, flared end first, onto the 4 wires.
- Slide the splices as far as they will go



12

- Align connector to SolderSleeves

Socket Connector (Part B)

Yellow (large tab)

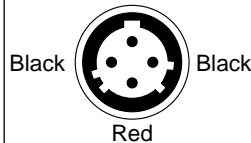

Pin Connector (Part A)

Yellow (large tab)

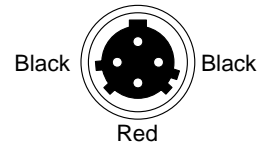

- Once yellow wire is aligned correctly, the red wire will be opposite to it and all wires will be in their correct positions.

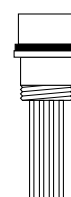
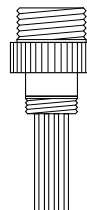

9
8
7
6
5
4
3
2
1

**TT-5000-CK-MC-M/F Field Installed Connectors for TT5000 Bulk Cable
Installation Instructions**

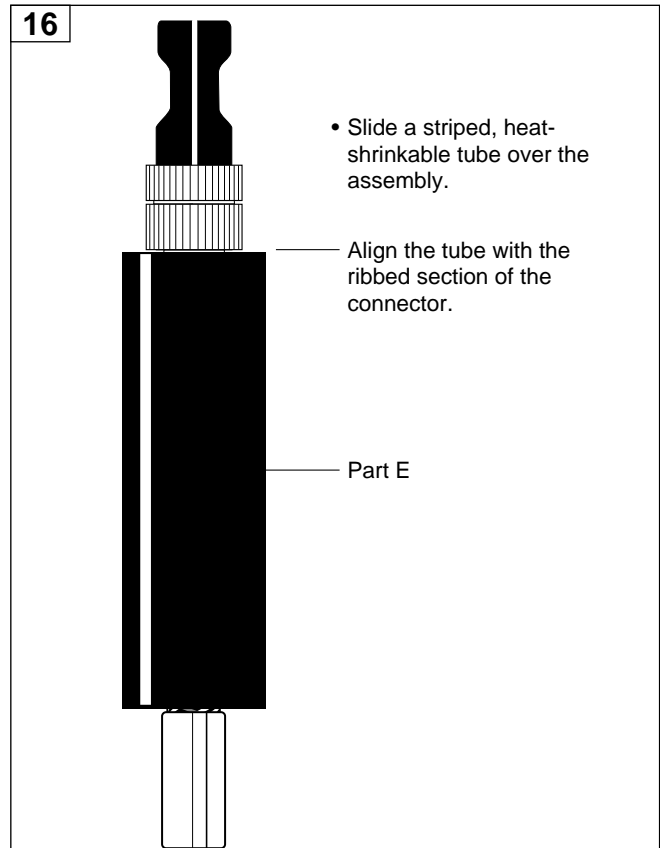
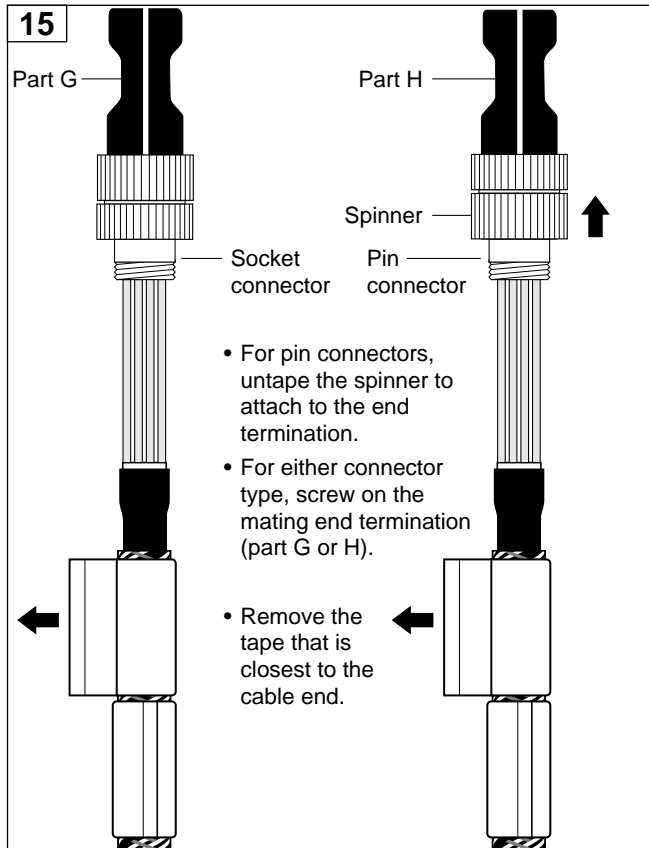
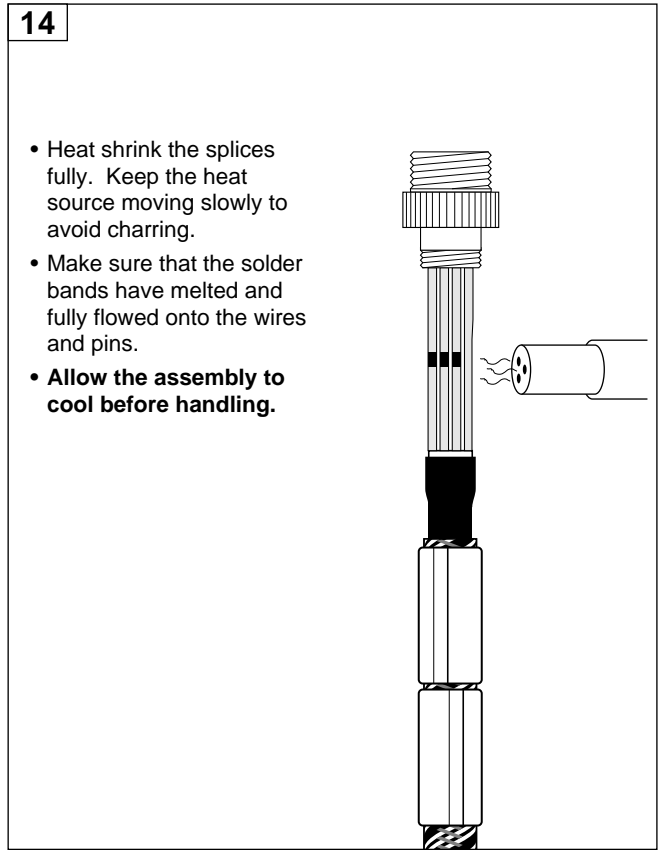
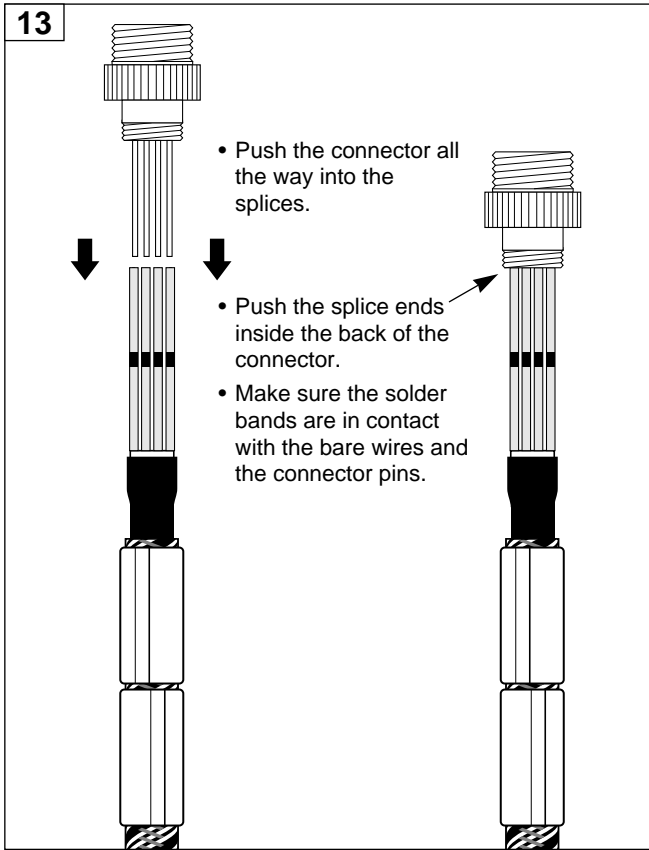

**TT-5000-CK-MC-M/F Field Installed Connectors for TT5000 Bulk Cable
Installation Instructions**

17

- Heat shrink 1/4" of the tube onto the connector, moving the torch around the tube to heat evenly.
- Leave a small gap between the tube and the ribbed section of the connector.

1/4" Leave a 1/16" gap

- **Do not overheat**
The tube may slip off of the connector if it is overheated.
- **Allow to cool before proceeding.**

18

- Heat shrink the rest of the tube, avoiding the already shrunk section.
- Once the tube is smooth, apply more heat at the midpoint of the tube to seal to the cable.

Do not reheat this area

Adhesive will flow from the end of the tube.

Do not heat fibers

19

- Remove the last piece of tape while the adhesive is still warm.
- **Allow the assembly to fully cool.**
- Remove the end termination.
- Test the connector assembly using the procedure in step 20 before proceeding.

For the pin connector, the spinner must turn freely.

If necessary, use pliers to break it free.

20 Test the Connector Assemblies



Opposite cable end from
the socket connector

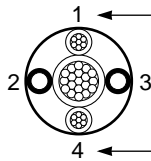

Opposite cable end from
the pin connector

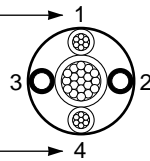

yellow

red

- Attach the mating test-tool-half to the connector to be tested.
- If both cable ends have connectors, attach a mating end termination at the opposite end. If there is no connector on the opposite cable end, prepare it according to steps 2 through 7 and twist together wires 1 & 2. Also join wires 3 & 4.
- Use an ohmmeter to measure the resistance between the test tool pins.
- The resistance between the 2 longest pins or the 2 shortest pins should be $\approx 4x$ cable length (ft.) (i.e. A 100 ft. cable should measure $\approx 400\Omega$ between the two longest pins and $\approx 400\Omega$ between the two shortest pins.)
- The resistance between the 2 intermediate length pins should be greater than 20 MEG Ω .
- If the assembly fails any of the resistance tests;
 - 1) Check the twisted wires at the opposite cable end.
 - 2) Check for any pinches in the sensing cable at the access points.
 - 3) If necessary, cut off and discard the connector and install a new one.

21 Apply Environmental Seal

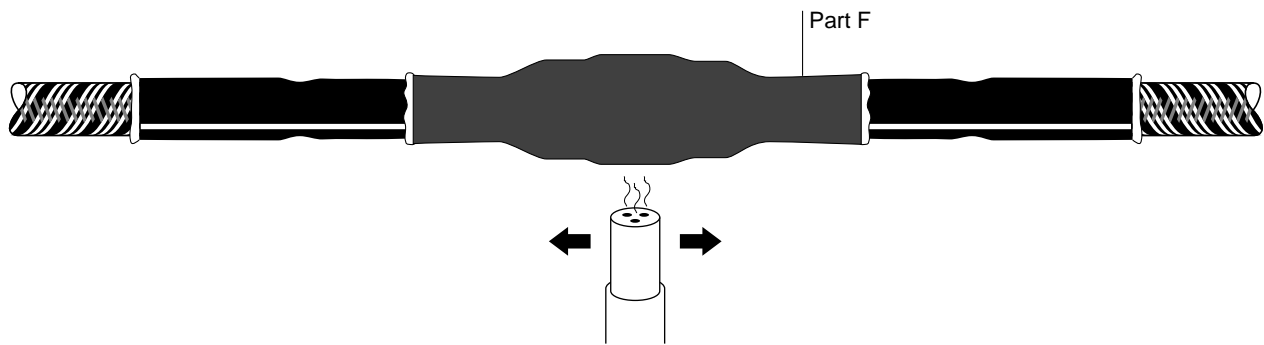

- Before mating the connector assemblies, slide the non-striped tube onto one of the cables. Connect the pin and socket connectors together firmly. Center the non-striped tube over the pin/socket connection. Heat shrink the tube over the connection, beginning in the center and shrinking towards the ends until the tube fully conforms to the shape of the connection and adhesive flow from each end of the tube.
- **Let the entire connector area cool before handling the cable.**

**TT-5000-CK-MC-M/F Field Installed Connectors for TT5000 Bulk Cable
Installation Instructions**

**TT-5000-CK-MC-M/F Field Installed Connectors for TT5000 Bulk Cable
Installation Instructions**

Raychem Corporation
Commercial & Industrial Infrastructure Division
300 Constitution Drive
Menlo Park, CA 94025-1164
Tel (800) 545-6258
Fax (800) 611-2323
Fax-on-Demand (800) 329-4494
ciinfo@raychem.com
www.raychem.com