

INSTALLATION INSTRUCTIONS

Product Information

SZA
115Vac +15%, -20%; 50/60 Hz
230Vac ±10%; 50/60 Hz
12Vdc ±20%

Power consumption
7 watt maximum

Relays
Number: Three (2 x Leak, 1 x Fault)
Type: SPDT
Rating: 3 A at 250Vac/24 Vdc

Temperature
Storage: -18°C to 60°C (0°F to 140°F)
Operating: 0°C to 50°C (32°F to 122°F)

Enclosure
NEMA 12; IP54

Approvals
CE The SZA is approved for use in ordinary areas. The module must be located in an Ordinary Area, but may monitor intrinsically safe TraceTek sensing cables located in Hazardous Locations:

- TraceTek sensing cable in Class I, Division 2, Groups A, B, C, D Hazardous Locations.
- If protected by agency-approved zener barrier TraceTek sensing cable in Class I, Division 1, Groups A, B, C, D Hazardous Locations (Zone 0 or Zone 1 in Europe). Contact your TraceTek distributor/agent to select proper zener barrier.

Maximum Circuit length
100m (328ft) TraceTek sensing cable or 10 water or optical oil probes per zone. Leader and jumper cable lengths are not included in this limitation.

General Information

Please read these instructions carefully and keep them in a safe place (preferably close to the module) for future reference. These instructions must be followed carefully to ensure proper operation.

The SZA single zone alarm has been designed specifically for use with TraceTek sensing cables (TT1000, TT3000, TT5000, TT5001 and TT7000). The SZA can monitor up to 100 m (328 ft) of sensing cable, or 10 water detection probes. Optical probes, float switches and level indicators can also be incorporated into the system.

The SZA is designed for use in ordinary areas with temperatures of 0°C to 50°C (32°F to 122°F).

Installation items (not supplied)

- Wall fasteners for surface mounting (four screws)
- Rubber or elastomeric washers to seal at mounting points
- Semi-flush recess flange (optional)

Tools required

- Drill or hole punch for electrical conduit entries
- Phillips (cross-head) screwdriver
- Small flat-head screwdriver

Storage

Keep the module in a dry place prior to installation to avoid possible damage to internal components.

Additional items

- AT-BU Battery Unit c/w battery for 72 hrs operation
- AT-BAT Replacement 12Vdc, 7Ah Battery
- AT-SZA-SFMF Semi Flush Mounting Flange

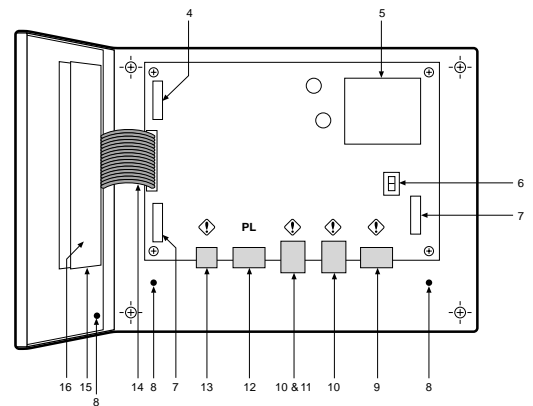
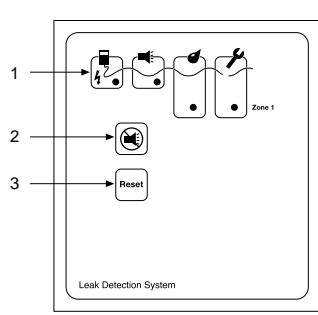

- | | | | |
|--------------------|-------------------------------------|---------------------------------------|------------------------|
| 1. LEDs with icons | 5. Motherboard | 9. Power cable terminal block | 13. Battery connection |
| 2. Silence key | 6. Voltage selector (110 or 220Vac) | 10. Leak relay cable plug and socket | 14. Ribbon cable |
| 3. Reset key | 7. Fuse (1600mA, 250 V) | 11. Fault relay cable plug and socket | 15. Buzzer mute link |
| 4. Spare fuse | 8. Ground/earth stud | 12. Sensing cable plug and socket | 16. Display door board |

⚠ WARNING: Shock hazard. Shut off power before opening enclosure door.
PL Indicates power limited circuits.

Note: To avoid damage to the unit, store the SZA module in its cardboard box until construction is complete.

Select the mounting position

Choose a location indoors where the module will be protected from the elements and temperature extremes.

WARNING: Ignition hazard. Do not mount the SZA unit in a hazardous location. Sensing cable connected to the SZA may (subject to approvals restrictions) be located in hazardous locations, but the module itself must be in an ordinary area.

Prepare the module for mounting

Important: The SZA is an electronic unit. During installation, take the following precautions to avoid damage to its electronic components:

- Handle with care, avoid mechanical damage.
- Keep the electronics dry.
- If handling circuit boards, hold them by their edges to avoid physical contact with electronic components.
- Avoid exposure to static electricity.
- Avoid contamination with metal filings, liquids, or other foreign matter.

- Remove the module from its packaging.
- Open the enclosure door using a flat-blade screwdriver or coin.
- Carefully disconnect the ribbon cable from the motherboard.
- Unscrew the four Phillips (cross-head) screws holding the motherboard to the enclosure (see Fig 1). Remove the motherboard, and put it out of harm's way.
- Taking care to protect the User Interface board on the enclosure door, drill/punch entries as required (see Fig 2).
- **Note:** The TraceTek sensing circuit is power limited, so the TraceTek leader or jumper cable and the power supply cable must not run in the same conduit.
- Fit conduit bushings/adapters.
- Remove all traces of metal filings and dust from inside the module enclosure.

Mount the module

The module mounts with four screws with mounting centers as noted in Fig 3. To seal around the mounting screw (necessary to maintain the IP54 rating), use a rubber or elastomeric washer.

Reassemble the module

Note: before replacing the motherboard, ensure that the interior of the enclosure is clean.

- Replace the motherboard and secure it in place with the Phillips (cross-head) screws.
- Reconnect the ribbon cable (taking care not to bend any pins in the connection).
- Close and secure the door of the enclosure.

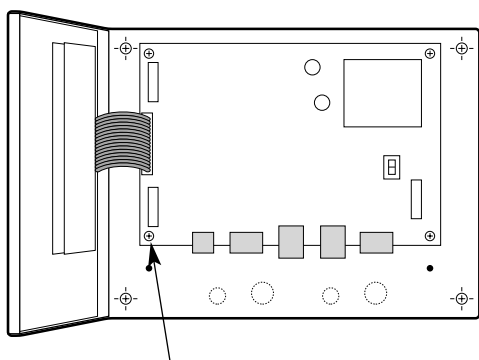

Figure 1 Remove all four screws attaching motherboard

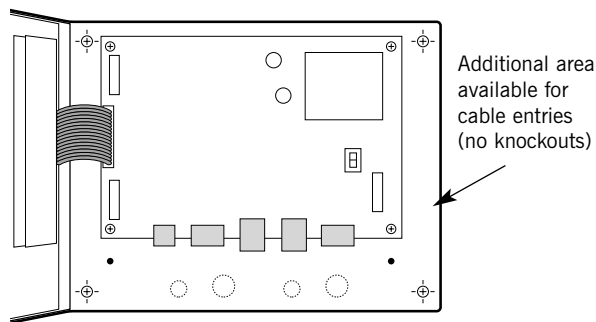

Figure 2

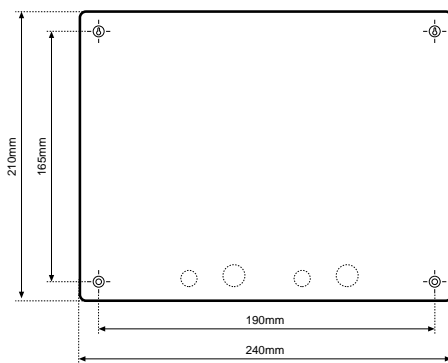

Figure 3

Cable entry knockouts are provided as follows:
 Back plate 2 x 20mm and 2 x 3/4"
 Base of enclosure 3 x 20mm and 3 x 3/4"

Connecting the Power Cable and Relays

Connect the power wiring

- Open door of SZA enclosure.
- Pass the power cable through the knock-out/adaptor/bushing if fitted.
- **Note:** Proper grounding/earthing is important to avoid the possibility of electromagnetic interference.
- Connect the power supply wires to the special three-pin terminal block marked ENL (Earth, Neutral, Live), observing the polarity.
- The electrical supply should be fused at no more than 3amps via an un-switched fused spur adjacent to the unit.
- **Note:** Set the voltage selector switch to the required voltage 220 or 110Vac. The terminals can accept wires 12 to 24 AWG.
- **Note:** Do not exceed maximum voltage.

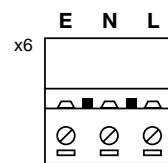

Figure 4

Battery Back-Up

- The unit is equipped with a 12Vdc battery back-up power circuit. If this option is required connect the + and - (positive and negative) battery leads as indicated below (fig 5).
- A separate battery enclosure is available AT-BE which will house a 12Vdc 7Ah battery - AT-BAT.
- Batteries should be tested, maintained and replaced in accordance with the battery manufacturers instructions and recommendations.

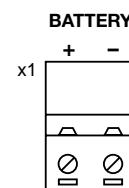

Figure 5

Connect the alarm / break relays

The SZA has three alarm relays, 2 x leak and 1 x cable break. Each relay provides Form C relay contacts, normally open and normally closed. The relays are **energised** to indicate an alarm condition. Each relay is independent of the next. The illustration below shows the relay status when in the alarm (energised) state.

Note: The relay plugs can accept wires 12 to 24 AWG. Cable should have a temperature rating of 65°C.

Note: Maximum load for relays is 3 amps.

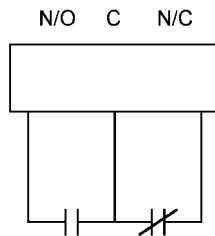

Testing the Module

Test after supplying power

- Close and latch the enclosure door.
- Supply power to the unit. When power is supplied, the green LED illuminates for mains power (red for battery supply). After the start-up sequence is complete, the module should report a fault alarm (this is normal: there is no sensing cable attached). Press the red Silence key to silence the audible alarm. Verify that the red Alarm and yellow Cable Break LED's are illuminated.

If anything other than the above occurs, check all connections.

If the unit still does not appear to operate properly contact your supplier for assistance.

Connecting the Sensing Cable

Prepare sensing cable / sensing probe / other devices

Ensure that the sensing cable (sensing device) has been installed in accordance with the instructions provided.

Make connections

- Confirm that the power to the unit has been shut off.
- Open the enclosure door.
- Feed the end of the TraceTek modular leader cable (or jumper cable) through the knockout / adapter / bushing if fitted.
- Connect the four colour-coded wires to the Sensor Interface plug.

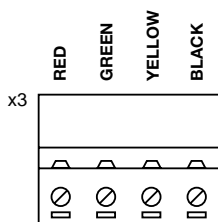

Important: Observe the colour coding. If wires are not connected to the proper terminals, the leak detection system cannot operate properly.

- Insert the sensing cable (SI) plug into the SI socket (item 12 on the product illustration on the first page).

Install Zener barrier, if applicable

When sensing cable will be located in Class 1, Division 1 locations, approval agencies require that the sensing cable be protected with a zener barrier between the sensing cable and the SZA module. A zener barrier may also be used to provide lightning protection for the module when the sensing cable may be exposed to electrical discharges. Contact your distributor / agent to select the proper zener barrier.

When installing a zener barrier, wire it in accordance with the instructions provided with the kit.

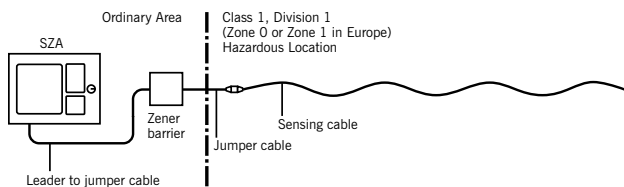

Start-Up and System Testing

Power up the system

Note: Check the voltage selector switch has been set to the correct country / application voltage.

After connections are complete supply power to the unit. If the sensing circuit is complete and free of leaks or other problems, the green monitoring LED will illuminate only.

If this is not the case, you can find additional information in the SZA Operation and Maintenance Manual supplied with the module.

Commissioning

Your system should be commissioned by an authorised Aquitrone™ or TraceTek representative. The system map is a crucial part of the system and should be located adjacent to the unit and within the O&M documents.

Important: Store hardware and documentation supplied with the SZA in a secure place for later use (commissioning, connecting interfaces, operating).

Important: All information, including illustrations, is believed to be reliable. Users, however, should independently evaluate the suitability of each product for their application. Aquilar Limited makes no warranty as to the accuracy or completeness of the information, and disclaims any liability regarding its use. The only obligations of Aquilar Limited are those in the Aquilar Standard Terms and Conditions of Sale for this product, and in no case will Aquilar Limited be liable for any incidental, indirect, or consequential damages arising from the sale, resale, use or misuse of the product. Specifications are subject to change without notice. In addition, Aquilar Limited reserves the right to make changes - without notification to Buyer - to processing or materials that do not affect compliance with any applicable specification.

Aquitrone is a trademark of Aquitrone Limited
Aquilar is a trademark of Aquilar Limited
TraceTek is a trademark of Tyco Thermal Controls

Aquilar Limited
Dial Post Court, Horsham Road,
Rusper, West Sussex RH12 4QX. UK
Tel: + 44 (0) 1293 871874
Fax: +44 (0) 1293 871717

E-mail: info@aquilar.co.uk
www.aquilar.co.uk

Master TraceTek Distributor UK & Ireland for
Raychem® TraceTek®
Water, Fuel and Chemical Leak Detection